



QUALITY YOU CAN TRUST

# USER'S MANUAL



## BON APPETIT STANDMIXER

# CONTENTS

WELCOME TO YOUR NEW KITCHEN ASSISTANT!	1
IMPORTANT	2
GETTING TO KNOW YOUR BON APPETIT STANDMIXER	5
MEAT GRINDER FUNCTION	8
SAUSAGE FUNCTION	10
VEGETABLE SLICER FUNCTION	12
PASTA MAKER FUNCTION	14
FAULT CODES	16
CLEANING	17
TECHNICAL SPECIFICATIONS	18
WARRANTY TERMS AND CONDITIONS	19
CONTACT US	20

# WELCOME TO YOUR NEW KITCHEN ASSISTANT!

Congratulations for investing in a professional quality Optimum Bon Appetit. Your new Standmixer is suitable for use in the domestic environment and you'll very quickly see why we describe it as "your new kitchen assistant".

From the first time you use your Optimum Standmixer, it will become your "secret ally", helping you to cook like a five-star chef. Its many diverse functions will help you to prepare healthy, nutritionally balanced meals in half the time you'd expect.

Use it to create an amazing range of fresh, tasty, nutrient-rich foods, including Cakes, pastries, cookies, frosting, biscuits, ice cream, meat loaf and so much more

**FOR BEST RESULTS, AND TO ENSURE YOUR SAFETY,  
PLEASE READ THE INSTRUCTIONS IN THIS MANUAL CAREFULLY.**

# IMPORTANT

## GENERAL SECURITY INSTRUCTIONS

**Read the operating instructions carefully before putting the appliance into operation and keep the instructions including the warranty, the receipt and, if possible, the box with the internal packing. If you give this device to other people, please also pass on the operating instructions. Keep these instructions for use for future reference.**

1. The appliance is designed exclusively for private use and for the envisaged purpose. This appliance is not fit for commercial use.
2. Check if the voltage indicated on the appliance corresponds to the local mains voltage before you connect the appliance.
3. Appliances can be dangerous if they are used incorrectly. Please ensure that anyone who uses your Optimum Standmixer clearly understands how to operate it safely to avoid potential hazards.
4. Your Optimum Bon Appetit Standmixer is not a toy. Do not allow children to use it; and keep it and the cord that comes with it out of their reach
5. Switch off your Optimum Standmixer and disconnect it from any power supply before you change the accessories or handle any moving parts.
6. Do not insert the mains plug of the machine into the power socket without having installed all the necessary accessories.
7. When cleaning or putting away, or if the appliance is not being used, switch off the appliance and always pull out the plug from the socket (pull on the plug, not the cable) and remove the attached accessories.
8. Do not operate the machine without supervision. If you should leave the workplace, always switch the machine off or remove the plug from the socket (pull the plug itself, not the lead).
9. Check the appliance and the cable for damage on a regular basis. Do not use the appliance if it is damaged. Do not try to repair the appliance on your own. Always contact an authorized technician. If the supply cord is damaged, it must be replaced by the manufacturer, its service agent or similarly qualified persons in order to avoid a hazard.
10. Any damage to components – including the main body, mixing bowl, dough hook – can make your Optimum Standmixer less safe to use. Regularly check all components for damage, and if you find something wrong, please stop using the appliance and contact our After Sales Service centre.
11. Accessories, other than those supplied with the appliance, should not be used when operating the Optimum Bon Appetit. Misuse may damage your appliance and void your warranty
12. Do not use it outdoors.
13. Keep it away from sources of heat, direct sunlight, humidity and sharp edges.
14. Do not use the appliance with wet hands (never dip it into any liquid). If the appliance is humid or wet, unplug it immediately to avoid electrical shock.
15. Thoroughly clean the parts that will come into contact with food before you use the appliance for the first time.
16. Always put the main appliance on a flat, dry and clean surface.
17. Do not let cord hang over edge of table or counter, or touch hot surfaces.

18. Don't use your attachment and/or appliance if it has been damaged. You should contact an approved service centre.
19. Dropping your Optimum Standmixer or allowing it to fall can seriously damage it. Please place it on a stable, flat, heat-resistant surface (e.g. a bench or table); and ensure that it is at a safe distance from the edge to avoid falling. Please be aware that when you use the unit to knead dough or cut food, vibration may cause it to move; so do not leave it operating unsupervised.
20. If your Optimum Bon Appetit stops unexpectedly or appears to malfunction, switch off the power supply, unplug it from the mains, and stop using it immediately. Seek professional advice from the manufacturer, its service agent, or a similarly qualified person to identify the fault and make any repairs
21. In order to ensure your children's safety, please keep all packaging (plastic bags, boxes, polystyrene etc.) out of their reach. **Caution!** Do not allow small children to play with the foil as there is a **danger of suffocation!**
22. When using the accessory meat grinder and vegetable slicer, the appliance must not be used by children. Keep the appliance and its cord out of reach of children.
23. When using the accessory beater and whisk, the appliance can be used by children aged 8 years and above if they have been given supervision or instruction concerning the use of the appliance in a safe way and if they understand the hazards involved. Cleaning and user maintenance shall not be made by children unless they are aged 8 years and above and are supervised. Keep the appliance and its cord out of reach of children aged less than 8 years.
24. The appliance can be used by persons with reduced physical, sensory or mental capabilities or with a lack of experience and knowledge if they have been given supervision or instruction concerning the use of the appliance in a safe way and if they understand the hazards involved.

**CAUTION:** In order to avoid a hazard due to inadvertent resetting of the thermal cut-out, this appliance must not be supplied through an external switching device, such as a timer, or connected to a circuit that is regularly switched on and off by the utility.

25. Do not interfere with any safety switches.
26. Do not insert anything into the rotating hooks while the machine is working.

**CAUTION:** Ensure that the blender is switched off before removing it from the stand.

27. Avoid contacting moving parts. Keep hands, hair, clothing, as well as spatulas and other utensils away from the chute/mixer during operation to prevent injury, and/or damage to the mixer.
28. Do not operate mixer unattended or near edge of work surface. When used for heavy loads or at high speeds, mixer may move on work surface.
29. Do not place hands, fingers, or utensils in the bowl of the appliance unless the appliance is unplugged and the motor has come to a complete stop.
30. To avoid personal injury never use hands or fingers to push along the product in the meat grinder/ sausage maker/ vegetable slicer attachment. Use the recommended pusher to push the product through the feeder and prevent injury to hands and fingers.

31. Should scraper or other object drop into chute or bowl, turn motor OFF before removing to avoid personal injury and damage to the machine.
32. The use of attachments not recommended by Optimum may cause fire, electrical shock, or injury.
33. Do not use outdoors.
34. Please note that the tilt-head must be completely down before locking. Before mixing, make sure lock is in position by attempting to raise head.
35. Do not use an extension cord.
36. When making dough with the mixer, never operate mixer continuously for more than 10 minutes.
37. Be certain the attachment hub is secure (tighten attachment knob) prior to using mixer to avoid any possibility of the attachment hub falling into the bowl during mixing.
38. Be careful when lifting mixer as it is heavy.
39. Use the mixer only for its intended function.

**ELECTRICAL REQUIREMENTS:** Your Optimum Standmixer operates on a regular 220-240 volt A.C., 50 hertz house current. The wattage rating is determined by using the attachment that draws the greatest power. Other recommended attachments may draw significantly less power

**IMPORTANT: FAILURE TO FOLLOW THESE SAFETY INSTRUCTIONS AND WARNINGS COULD RESULT IN SERIOUS INJURY. ADDITIONALLY, MISUSING YOUR OPTIMUM STANDMIXER MAY DAMAGE IT AND VOID YOUR WARRANTY.**

# GETTING TO KNOW YOUR BON APPETIT STANDMIXER

## PARTS EXPLAINED

This section introduces you to the key components of your new Bon Appetit Standmixer.

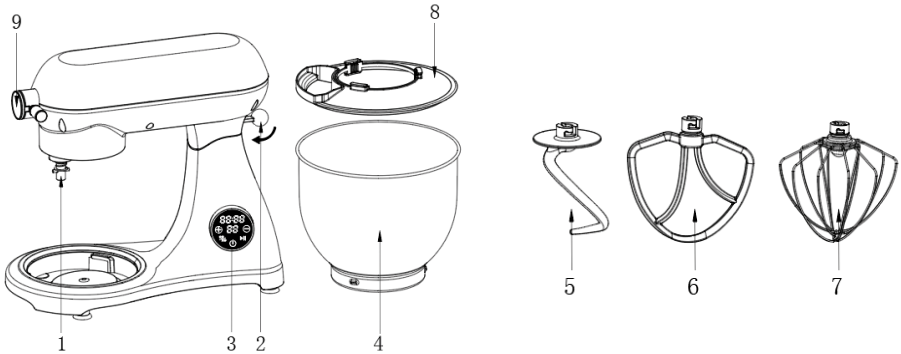

## MAIN PARTS AND STANDARD PARTS

1. Beater Shaft
2. Tilt -Head Handle
3. LED Display
4. Mixing Bowl
5. Dough Hook
6. Beater
7. Whisk
8. Splash Guard
9. Attachment Outlet Cover & Knob



## HOW TO USE THE MACHINE – BASIC OPERATION

1. Before use, wipe the exterior of the mixer with a clean damp cloth and wash the accessories with warm soapy water, rinse and dry thoroughly. Place the mixer on a flat and stable surface for operation.
2. To lift the machine head, press the tilt head handle (2) downwards, (step 1) the upper body will lift up automatically. (PG 1 & 2)
3. Place the splash guard into position on the head and rotate to secure (step 2). (PG 2).
4. Place the mixing bowl onto the stand (step 3) and rotate the bowl clockwise until it locks into place (step 4). (PG3)
5. Install your required accessory (5, 6 or 7) by inserting the top into the beater shaft, and turning counterclockwise to lock into position (step 5 & 6) (PG 4 & 5).
6. Add your desired ingredients into the bowl. Do not overfill the bowl or exceed the amount of dough (max 1.5kg)
7. Lower the machine head by pressing the tilt head handle down and pushing the machine head downwards at the same time, to lock into place (step 7) (PG 6).

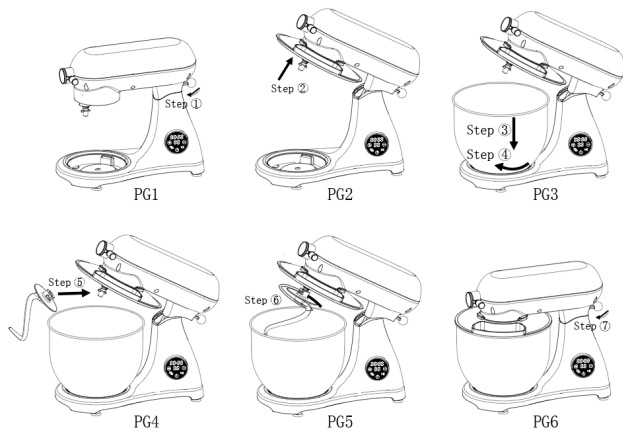
8. Insert plug into the power supply and press the power button to turn on. Select your desired speed and press start to begin mixing. When mixing is finished, press the power button to stop mixing and unplug the mixer.
9. Press the tilt head handle downwards to lift up the machine head, rotate the mixing bowl counter clockwise, remove from the stand and take out your dough or other contents.



## ADJUSTING THE LEVELS AND USING THE DOUGH HOOK FOR NO MORE THAN 1.5KG OF MIXTURE

Use	Picture	Levels	Time (Min)	Maximum	Operation Method
Dough hook		1-3	3-5	100g flour and 538g water	speed 1 run for 30s, then speed 2 run for 30s, and then speed 3 run for 2 - 3 min to form a smooth dough. Do not run for more than 10 minutes of continuous use.
Beater		2-7	3-10	660g flour and 840g water	speed 2 run for 20s, then speed 3-7 run up to a maximum of 10 minutes.
Whisk		8-10	3-10	3 egg whites (Minimum)	speed 8-10 run for 3 - 10 minutes maximum as needed.



# LED DESCRIPTION OF FUNCTION OPERATION



## 1. Switch on machine:



a. When plugged into the power supply, the display lights and flashes .

The Touch display is now in standby mode .











b. In standby mode, if no action for 1 min, the display will dim and enter dormant mode.

c. When dormant, touch  to wake up, the screen relights and enters standby mode.

## 2. Speed adjustment mode:

In standby and working mode, touch  or  speed shall change accordingly. Touch  Machine runs to display speed, touch again and the machine will pause function. You can adjust speed during working mode.

## 3) LED timer:

After you have selected your desired speed, touch  time numbers will flicker, touch  or  time changes accordingly. After the timer is set, touch  the machine will start and count down. When the timer gets to "0", the machine beeps and stops working, During working mode, touch  to pause function. The speed can be changed (touch  or ) and time adjusted (touch  then  or ) touch  once more and the machine will resume working mode.

**Note:** Timer can also be left unset and once speed is selected press the play/pause button and timer will count up, pause or stop when sufficient mixing is achieved. Do not allow to run for more than 5 minutes continuously.

# MEAT GRINDER FUNCTION

(\*OPTIONAL ATTACHMENT - Available for purchase via our website)

## HOW TO ASSEMBLE AND USE THE MEAT GRINDER

- 1) To install the meat grinder accessories, first remove the attachment outlet cover from the machine head (PG2) by loosening the screw turning anti-clockwise and removing the cap. Now align the meat grinder housing M3 into the outlet port and tighten the screw clockwise until the attachment is firmly in place, place the auger M4 into the housing and push until secure, then put the grinder blade M6 on the head of the auger, followed by your selected grinder plate M7, ensuring it aligns in the grooves and sits securely. Finally, tighten the mincing cap M5 onto the grinder housing.
  - 2) Align the discharge port of tray M1 with the feed port of meat grinder M3 and install it in place (PG4)
  - 3) Place a container at the outlet of the meat grinder. Cut the meat into small strips or pieces able to fit through the feed tube. The width should not exceed the feed inlet of the tray M2. (Use cold or partially frozen meat for best results)
  - 4) Plug into the power socket, then press the power button to turn on, set the speed to 3 and press play/pause button, put the meat on the tray M1 and feed it through the feeding port. Please use the pusher M1 to slowly press the meat into the feeding port of the meat grinder. Do not put your fingers into the meat grinder M3.
  - 5) Once finished, stop the machine function and unplug from the power supply.
- Note: When using the accessories, always keep the bowl in place to avoid risk of injury.

M1	Pusher
M2	Tray
M3	Meat Grinder Housing
M4	Auger
M5	Mincing Cap
M6	Grinder Blade
M7	Grinder Plate

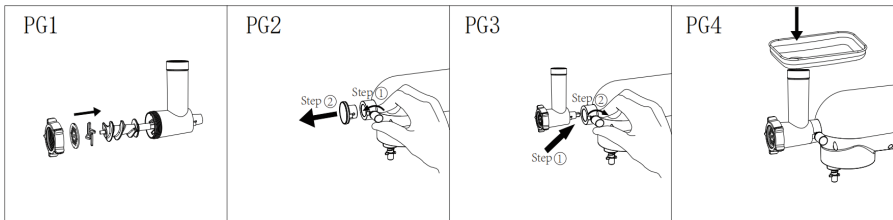
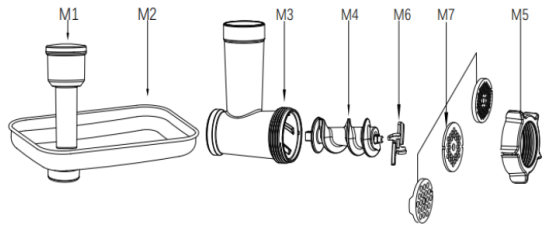

### Recipes suggestions:

Remove the bone out of the meat and cut the meat into 2.5cm pieces. Insert the plug into the socket, then set the speed control to 1-3, put the meat into the container, and it can work continuously for 3kg at one time. Please stop working after continuous operation for 5 minutes, do not work continuously for 15 minutes. So as not to affect the performance of the machine.

## **WARNING**

### **PERSONAL INJURY HAZARD**

**To avoid personal injury never use hands or fingers to push along the product in the meat grinder. Use the recommended pusher to push the product through the feeder and prevent injury to hands and fingers. Should scraper or other object drop into chute or bowl, turn motor OFF before removing to avoid personal injury and damage to the machine.**

# SAUSAGE FUNCTION

(\*OPTIONAL ATTACHMENT - Available for purchase via our website)

## HOW TO ASSEMBLE AND USE THE SAUSAGE MAKER

- 1) To set up the sausage maker, first remove the attachment outlet cover from the machine head (PG2) by loosening the screw turning anti-clockwise and removing the cap. Now align the meat grinder housing M3 into the outlet port and tighten the screw clockwise until the attachment is firmly in place, place the auger M4 into the housing and push until secure, then put the sausage support S1 on the head of the auger, followed by the sausage stuffer plate with 3 larger holes and then your selected sausage stuffer S2, and securing in place with the mincing cap.
- 2) Prepare minced meat stuffing and add relevant seasonings as desired. Mix evenly by hand and marinate for at least 1 hour.
- 3) Prepare the casing. Before use, put the casing into water and tie a knot at the end. Insert casing on the front of the sausage maker S2.
- 4) Align the discharge port of tray M1 with the feed port of meat grinder M3 and install it in place. Turn on the unit and set the speed control to 3-6. Put the minced meat into the feeding tube, then gently pull the casing. When filled to the required length, tighten and tie it with a knot, and repeat for the remaining meat.
- 5) The sausage is best hung up and dried for a couple of hours before use. It does not need to be completely dried. It can also be frozen or cooked immediately.

Note: When using the accessories, always keep the bowl in place to avoid the risk of injury.

M1	Pusher
M2	Tray
M3	Meat Grinder Housing
M4	Auger
M5	Mincing Cap
S1	Sausage support
S2-1	Large sausage stuffer
S2-2	Middle sausage stuffer
S2-3	Small sausage stuffer

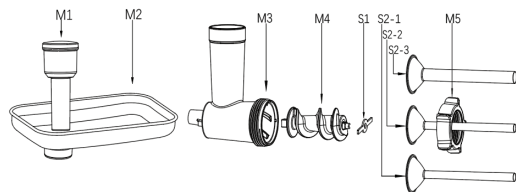

**Recipes suggestions:**

1kg pork, 16g salt, 70g sugar, 85g maple syrup, 2g white pepper, 7g garlic powder, 5g five spice powder, 15g black pepper, 50g potato starch and 90g yellow rice wine. After marinating the minced meat for an hour, insert the plug into the socket, and then set the speed control to 3-6. Please stop working after continuous operation for 5 minutes, do not work continuously for 15 minutes. So as not to affect the performance of the machine.



**WARNING**

**PERSONAL INJURY HAZARD**

**To avoid personal injury never use hands or fingers to push along the product in the sausage maker. Use the recommended pusher to push the product through the feeder and prevent injury to hands and fingers.**

**Should scraper or other object drop into chute or bowl, turn motor OFF before removing to avoid personal injury and damage to the machine.**

# VEGETABLE SLICER FUNCTION

(\*OPTIONAL ATTACHMENT - Available for purchase via our website)

## HOW TO ASSEMBLE AND USE THE VEGETABLE SLICER

- 1) Remove the attachment outlet cover (PG2) by loosening the screw by turning anti-clockwise and removing the cap.
  - 2) Align the vegetable cutting housing V2 into the outlet port and tighten the screw clockwise until the attachment is firmly secured, (PG3).
  - 3) Load the selected blade (fine shredder V3, coarse shredder V4, slicer V5) into the interior of the vegetable cutting housing V2, and turn slightly to lock into place (PG1).
  - 4) Place the container under the outlet of the housing.
  - 5) Cut potatoes or other vegetables into pieces that will easily fit inside the feed tube of the vegetable cutting housing.
  - 6) Insert the plug into the socket and set the speed to 3-5 and press start/pause. Push the vegetables into the inlet of the feeding tube and press gently with the pusher v1. (PG4)  
(Reminder: do not use fingers)
  - 7) Once finished, stop the machine function and unplug from the power supply.
- NOTE: For best results, feed only one item at a time into the feed tube. Do not feed items into the feed tube by hand; always use the food pusher. If food remains in the Slicer/Shredder attachment after running, pause the function, remove the remaining items, and place back into the feed tube to shred or slice again, resume operation.
- Note: When using the accessories, always keep the bowl in place to avoid risk of injury.

V1	Pusher
V2	Vegetable Cutting Housing
V3	Fine shredder
V4	Coarse shredder
V5	Slicer

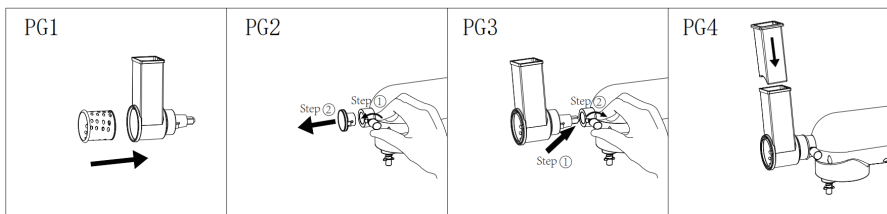
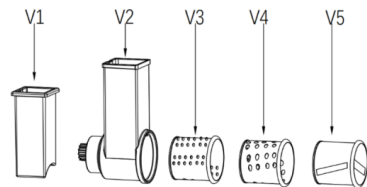

### Recipes suggestion:

Cut the solid food into long strips, pass through the feed tube, insert the plug into the socket, set the speed control to 3-5, and then apply appropriate force with the pusher to press the food through. Please stop working after continuous operation for 5 min, do not work continuously for 15 min. So as not to affect the performance of the machine.



## WARNING

### **PERSONAL INJURY HAZARD**

**To avoid personal injury never use hands or fingers to push along the product in the vegetable slicer. Use the recommended pusher to push the product through the feeder and prevent injury to hands and fingers. Should scraper or other object drop into chute or bowl, turn motor OFF before removing to avoid personal injury and damage to the machine.**

# PASTA MAKER FUNCTION

(\*OPTIONAL ATTACHMENT - Available for purchase via our website)

## HOW TO USE THE PASTA MAKER

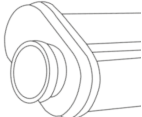
Pull out and rotate to select desired setting	Roller settings chart	Suggested use
	1-2	Kneading and thinning dough
	3-4	Egg noodles
	4-5	Spaghetti, Fettuccine, lasagna noodles
	6-7	Thin fettuccine, Tortellini, Linguine

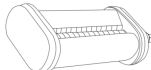
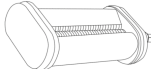
Attachment	Function	Speed	Noodle width
	Pasta Roller	2-6	Up to 140mm
	Fettuccine Cutter	2-6	6.5mm
	Spaghetti Cutter	2-6	2mm

## BEFORE FIRST USE

To avoid damage, do not wash or immerse the attachment in water or other liquid. Do not wash in the dishwasher. Note: These attachments are designed for making pasta dough only. Do not cut or roll anything other than pasta to avoid damaging your pasta maker.

## ASSEMBLING & USAGE

- 1) Remove the attachment outlet cover 9 by loosening the screw by turning anti clockwise and removing the cap and then select the attachment that you require.
- 2) Begin with the pasta roller by inserting into the outlet port of the front cover, and tighten the screw clockwise until the attachment is firmly secured (Step 1) (PG1 & PG 2)
- 3) Pull out the pasta roller adjustment knob after the attachment is completely secured to the mixer and select the desired pasta thickness level you need. (PG3)
- 4) Plug the mixer into the power supply, turn it on and set the speed to 2-6. Feed flattened dough into rollers to knead.(PG4)
- 5) Once finished, stop the machine function and unplug from the power supply.



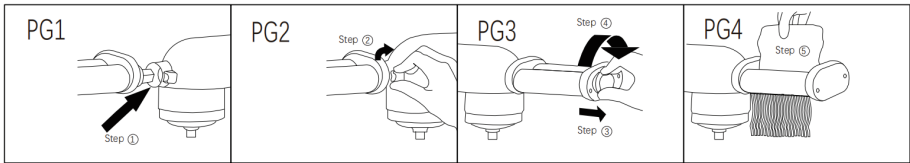

**⚠ WARNING**

**PERSONAL INJURY HAZARD**  
**To avoid personal injury keep fingers clear of cutters and rollers!**  
**Should scraper or other object drop into the rollers, turn motor OFF before removing to avoid personal injury and damage to the machine.**

**ATTENTION:**

1. Cut dough into sections that fit in the pasta roller.
2. Pull the pasta roller adjustment knob straight out and turn to setting 1. Release the knob, making certain the pin on the pasta roller housing engages the opening on the back of the adjustment knob, allowing the knob to fit flush against the roller housing.
3. Feed flattened dough into rollers to knead. Fold the dough in half and roll again. Repeat until the dough is smooth and pliable and covers the width of the roller. Lightly dust pasta with flour while rolling and cutting to help with drying and separation.
4. Feed dough through rollers to further flatten the sheet of dough. Change the roller to setting 3, and repeat the rolling process. Continue to increase roller setting until desired thickness is reached. Do not fold the dough during this step.
5. To make noodles, exchange the pasta roller for the cutter of your choice. Feed the flattened sheets of dough through the cutter. See the "Function chart" to determine the correct thickness for each type of pasta.
6. You can dust the dough with dry flour if the noodles are too soft and become cracked.

# FAULT CODES

## ANALYSIS OF COMMON PROBLEMS

Problem	Cause	Solution
The machine suddenly stops working during use.	It may be that the machine runs too long, or the ambient temperature is too high, resulting in the machine's motor temperature being too high; the machine starts the overheating protection program, and automatic shutdown.	Turn off and unplug the power, and wait for the machine to return to room temperature before restarting (generally needs 15-30 minutes, the room temperature varies cooling time).
Excessive noise when the machine is running	The machine will work louder in high gear than in low gear. The amount of food being mixed is too large, resulting in overloading the machine. Voltage is unstable. Working time is too long.	Choose the right speed to stir food according to the recommendations in the manual Reduce the mixing volume and let the machine work according to the normal workload. If the voltage is unstable, wait for the voltage to stabilize before using. If the working time is too long, stop and cool down for a while before using.
The machine speed drops, or the speed is unstable	The room temperature is low, causing the lubricant in the machine to harden. The ingredients stirred are too hard and too much, resulting in too much load on the machine. Whether the voltage suddenly becomes low.	Remove the mixing bowl and let the machine idle for 5 minutes to soften the lubricant in the machine and restore the speed stability. Reduce the mixing volume and let the machine work according to the normal workload. When the voltage is stable, use the machine again.
Machine swaying and shaking when working	Check if the foot pad on the base is off. Whether the machine is placed on a smooth and flat countertop for use.	Check if the foot pad on the base is off. Place on a smooth and flat countertop for use
The machine head can't spring back to reset after putting on the anti-splash cover and mixing bowl	Check that the anti-splash cover is in place and the mixing bowl is assembled.	Rotate the anti-splash cover and assemble it in place, and assemble the mixing bowl in place.
Dough darkening found after use	Black powder falls onto the dough at the mixing head.	Please check that the mixing head and hook are dry and that no water or dust is present on the surface before use.

# CLEANING

<b>Body Cleaning</b>	<ol style="list-style-type: none"><li>1. Do not immerse the machine in the water. Do not use water to shower directly on top of the machine to prevent water from getting into the machine body to avoid short circuits, electric shock, leakage, rust, and other failures.</li><li>2. Do not use a dripping wet towel to wipe the machine</li><li>3. Do not use detergent/vinegar/salt and other corrosive, strongly acidic, strong alkaline cleaning products to clean the machine body, to avoid damaging the machine's surface.</li><li>4. Do not use sharp and rough tools such as wire balls to brush the accessories. Otherwise, it is easy to damage the surface of the accessories.</li></ol>
<b>Accessory Cleaning</b>	<ol style="list-style-type: none"><li>1. Do not put the cast aluminium parts into the dishwasher or wash them with corrosive, strongly acidic, or alkaline cleaning products. Please do not put them into the dishwasher for cleaning. (Except for stainless steel parts or surface-treated Teflon parts and electrophoresis parts)</li><li>2. Do not soak in detergent, salt water, vinegar, and other corrosive liquids; use warm soapy water to clean accessories, rinse well and dry thoroughly before next use.</li></ol>
<b>Special Cleaning</b>	<ol style="list-style-type: none"><li>1. The rotating output shaft will produce a bit of black residue due to high speed and friction when the machine is working. After each use, please clean it promptly with a damp cloth and keep the area dry.</li><li>2. Pay attention to the sharp blade and related sharp edge parts of accessories.</li></ol>
<b>Preservation and maintenance</b>	When not in use, you can cover the machine with a packaging bag and place it in a dry environment.

## **WARNING**

**ELECTRICAL SHOCK HAZARD**  
**ALWAYS BE SURE TO UNPLUG MIXER BEFORE CLEANING**  
**TO AVOID POSSIBLE ELECTRICAL SHOCK.**  
**Wipe mixer with a damp cloth. DO NOT IMMERSE IN WATER.**  
**Wipe off beater shaft frequently, removing any**  
**residue that may accumulate.**

# TECHNICAL SPECIFICATIONS

<b>Product</b>	Optimum Bon Appetit Standmixer
<b>Model</b>	BONMIX
<b>Rated voltage</b>	220~240V
<b>Rated frequency</b>	50Hz
<b>Rated power</b>	1200W
<b>Gross weight</b>	7.1kg
<b>Net weight</b>	6.5kg
<b>Dimension</b>	89 x 89 x 290mm (L x W x H)

## DISPOSAL



**Do not dispose of the device in normal domestic waste.**

At the end of its service life, this product may not be disposed of in the normal household waste, but rather must be disposed of at a collection point for recycling electrical and electronic devices. The materials are recyclable according to their labelling. You make an important contribution to protecting our environment by reusing, recycling or utilizing old devices in other ways. Please ask the municipal administration where the appropriate disposal facility is located.

# WARRANTY TERMS & CONDITIONS

The warranty outlined below only covers distributors of the Optimum range of appliances. Please contact your distributor for a full product warranty.

## Effective as of 1st January 2014

1. Optimum® (“we”) warrants this appliance to be free from defects in materials and workmanship. As long as you use it according to this instruction book, Optimum® warrants that it will perform satisfactorily in household use for a period of 1 year.
2. Any warranties beyond this standard period are offered as extended terms by the selling distributor. This means you can only claim them through that provider.
3. We will repair/replace your appliance if any defects occur under normal use and care within this manufacturers’ warranty period at our discretion, and only if the selling distributor cannot do so. This is done solely at our option with no charge for parts. This warranty does not extend to any accessories, whether included or purchased separately.  
If your distributor determines that your appliance has a major fault, they may offer a replacement at their own discretion.
4. If your appliance needs repair while it is under warranty, and your distributor cannot provide the repairs, you are responsible for the cost of returning it to us (or an approved service provider), and also for the cost of returning it back to you.
5. Whilst your appliance is in transit, you assume all risk for it. The warranty does not cover any further damage during transportation.
6. You must ensure that you properly package your appliance when you return it to avoid any damage to it during transit.
7. To enable us to process your warranty claim, ensure you include an explanation of any problem. We will not look for faults for you, and will only repair described faults as covered under warranty.
8. This full warranty is void if your appliance has been subjected to abuse, negligence, accident, alteration, failure to follow operating instructions, or exposed to abnormal or extreme conditions.
9. Cosmetic changes that do not affect performance will not be considered defects or fall under this warranty. These changes include discolouration of any parts of your appliance, or the effects of using abrasive cleaners. The warranty does not cover cleaning or removing any food products from your appliance, or repairing any damage caused by allowing them to build up.
10. This warranty does not cover normal wear and tear on your appliance or its parts.
11. This warranty does not cover any defect caused by an accident, misuse, abuse, improper installation or operation, lack of reasonable care, unauthorised medication, loss of parts, tampering or attempted repair by anyone we have not authorised to make repairs.
12. The warranty will not apply if the damage, malfunction or failure results from alterations, accident, misuse, abuse, fire, liquid spillage, maladjustment of customer controls, use on an incorrect voltage, power surges and dips, thunderstorm activity, acts of God, voltage supply problems, tampering or unauthorised repairs by any persons, use of defective or incompatible , exposure to abnormally corrosive conditions or entry by any insect, vermin or foreign object in the product.
13. The warranty does not cover damage from using your machine with an alternate power source (e.g. solar, inverter, generator, etc.). We do not recommend using these devices to power your appliance.
14. You must keep your purchase docket/receipt as both proof of purchase, and proof of the date on which you made the purchase. You will need to present your purchase docket or receipt when making a claim under this warranty.
15. If you do not present your receipt of purchase, this warranty is invalid. Consumer Law allows us to request reasonable proof of purchase to service a warranty claim.
16. This warranty does not imply, intend to or detract from any consumer rights listed in, and able to be enforced from, Regulated Consumer Law. If any condition is found to be in breach of the Consumer Law, only that single condition shall be void; and all other conditions will remain in place.

# CONTACT US

Please contact the distributor located in the country where you made your original purchase for all Support, Servicing and Warranty

